

# S2770/3370/3970RT

## COMPACT ROUGH TERRAIN SCISSOR LIFTS



- Compact diesel rough terrain scissor lifts
- Excellent rough terrain performance
- Easy to operate
- Roll-out deck extension for extra reach
- Ideal for outdoor work in confined spaces

**snorkel**  
[www.snorkellifts.com](http://www.snorkellifts.com)

# COMPACT RT SCISSORS

# S2770/3370/3970RT

DIMENSIONS	S2770RT	S3370RT	S3970RT
Max. working height	10.23m	12.1m	13.9m
Max. platform height (A)	8.23m	10.1m	11.9m
Platform size (stowed) (B)	2.71m x 1.65m	2.71m x 1.65m	2.71m x 1.65m
Platform size (extended) (C)	3.9m x 1.65m	3.9m x 1.65m	3.9m x 1.65m
Deck extension length	1.2m	1.2m	1.2m
Overall width (D)	1.8m	1.8m	1.8m
Overall length (E)	3.4m	3.4m	3.4m
Stowed height (F)	2.59m	2.7m	2.95m
Min. height (guardrails folded)	1.83m	2.0m	2.13m
Ground clearance	330mm	330mm	330mm

PERFORMANCE	S2770RT	S3370RT	S3970RT
Platform capacity (SWL)	580kg	450kg	350kg
Max. drive height	8.23m	10.1m	11.9m
Max. wind speed	12.5m/s	12.5m/s	12.5m/s
Max. drive speed (stowed)	4.5km/h	4.5km/h	4.5km/h
Max. drive speed (elevated)	0.5km/h	0.3km/h	0.3km/h
Raise/lower time	26/30 sec	50/60 sec	50/60 sec
Gradeability	45%	45%	45%
Max. outrigger levelling, front to rear	6°	6°	6°
Max. outrigger levelling, side to side	10°	10°	10°
Inside turning radius	2.44m	2.44m	2.44m
Outside turning radius	4.75m	4.75m	4.75m
Tyres	27 x 10.5 - 15 non-marking		
Controls	proportional joystick		
Drive system	4 wheel drive		

POWER	S2770RT	S3370RT	S3970RT
Power source	Kubota D-902 water-cooled diesel 22.5hp Tier 4 Final		

WEIGHT	S2770RT	S3370RT	S3970RT
Weight	2,800kg	3,620kg	3,790kg

## TURNING RADIUS

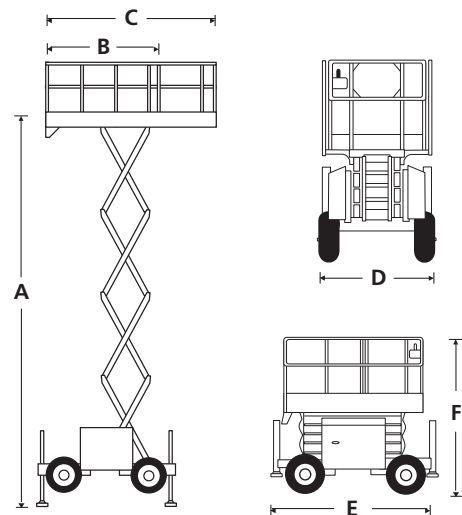
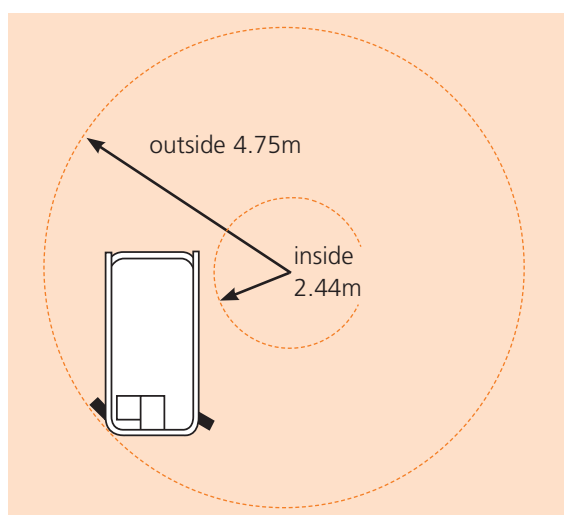

## STANDARD FEATURES

- 4 wheel drive
- 4 hydraulic outriggers with automatic levelling
- Roll-out deck extension
- Non-marking tyres
- Proportional controls
- Power line to platform
- Drive motion alarm
- Descent alarm
- Manual lowering valve
- Flashing amber light
- Oscillating axle
- Fold-down guardrails
- Hour meter & on-board diagnostics display
- Dual lanyard attachment points
- 2 year parts & labour, 5 year structural warranty
- CE approved

## OPTIONS

- Special paint colours
- LPG power
- Dual fuel
- Hydraulic generator 110V/240V
- Nylon spreader pads (set of 4)
- Environmental hydraulic oil

**snorkel**

Vigo Centre, Birtley Road,  
Washington, Tyne & Wear,  
NE38 9DA, U.K.

t: +44 (0) 845 1550 057  
e: sales@snorkellifts.com

www.snorkellifts.com